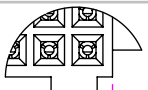

TABLE 1		
STYLE	"A"	"B"
-X1	.120 [3.05]	.020 [.51]
-X3	.075 [1.91]	.016 [.41]

DO NOT SCALE FROM THIS PRINT



SFML-1XX-XX-XXX-D-XXX

No OF POSITIONS  
-05, -07, -08, -10 THRU -50  
(PER ROW)

- LEAD STYLE**
- 01: THROUGH HOLE (USE C-44-01-XXX, SEE FIG 1, SHT 1)
  - 02: SURFACE MOUNT (USE C-44-02-XXX, SEE FIG 3, SHT 2)
  - 03: STRAIGHT MODIFIED (USE C-44-03-XXX, SEE FIG 1, SHT 1)
  - L1: THROUGH HOLE (LOW INSERTION) (USE C-61-01-XXX, SEE FIG 1, SHT 1)
  - L2: SURFACE MOUNT (LOW INSERTION) (USE C-61-02-XXX, SEE FIG 3, SHT 2)
  - L3: STRAIGHT MODIFIED (LOW INSERTION) (USE C-61-03-XXX, SEE FIG 1, SHT 1)
  - T1: THROUGH HOLE (PHOS BRONZE) (USE C-119-01-XXX, SEE FIG 1, SHT 1)
  - T2: SURFACE MOUNT (PHOS BRONZE) (USE C-119-02-XXX, SEE FIG 3, SHT 2)

- OPTIONS**
- (LEAVE BLANK FOR STANDARD AND USE SFML-XX-D)
- A: ALIGNMENT PIN (USE SFML-XX-D-A) (SEE FIG 5, SHT 3)
  - LC: LOCKING CLIP (SEE FIG 7, SHT 3) (USE (2) LC-05-TM & SFML-XX-D) (SEE NOTE 9)
  - P: PICK & PLACE PAD (SEE FIG 6, SHT 3) (USE PPP-02) (NOT AVAILABLE IN 5 POS)
  - TR: TAPE & REEL PACKAGING (N/A with -X1 AND -X3 LEAD STYLE, SEE FIG 2, SHT 1)
  - K: POLYIMIDE FILM PAD (USE K-DOT-.157-.250-.005) (SEE FIG 4, SHT 2)
  - SN: SOLDER NAIL (USE SFML-XX-D-SN & WT-27-01-T) (SEE FIG 8, SHT 4) (AVAILABLE ON -X2 LEAD STYLES ONLY)
  - SN2: SOLDER NAIL FOR .093 BOARD (USE SFML-XX-D-SN & WT-27-02-T) (SEE FIG 8, SHT 4) (ONLY AVAILABLE WITH -02, L2, AND T2 LEAD STYLE. NOT AVAILABLE WITH -A, -LC OPTIONS)

**ROW SPECIFICATION**

- D: DOUBLE ROW (USE SFML-XX-D-X)

**PLATING SPECIFICATION**

- S: 30µ" SELECTIVE GOLD IN CONTACT AREA, MATTE TIN ON TAIL
- F: 3µ" FLASH SELECTIVE GOLD IN CONTACT AREA, MATTE TIN ON TAIL
- H: 30µ" HEAVY GOLD IN CONTACT AREA, 3µ" GOLD ON TAIL
- L: 10µ" LIGHT SELECTIVE GOLD IN CONTACT AREA, MATTE TIN ON TAIL
- STL: 30µ" SELECTIVE GOLD IN CONTACT AREA, TIN/LEAD (90/10+/-5%) TAIL (ONLY AVAILABLE ON -02 AND -L2 LEADSTYLES)
- SM: 30µ" SELECTIVE GOLD IN CONTACT AREA, MATTE TIN ON TAIL
- LM: 10µ" LIGHT SELECTIVE GOLD IN CONTACT AREA, MATTE TIN ON TAIL
- FM: 3µ" FLASH SELECTIVE GOLD IN CONTACT AREA, MATTE TIN ON TAIL

FIG 1

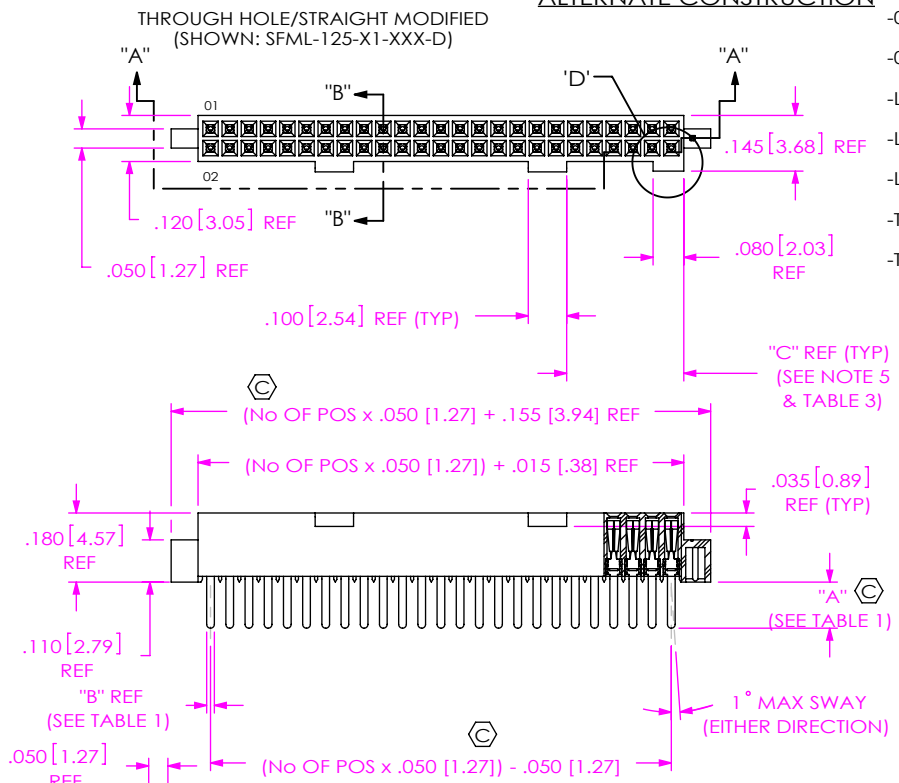

SFML-XX-D

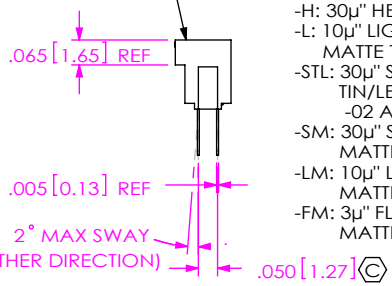

NOTES:

1. Ⓢ REPRESENTS A CRITICAL DIMENSION.
2. COPLANARITY: .004 [0.10] FOR POS. 04 THRU 26  
.006 [0.15] FOR POS. 27 THRU 50
3. MINIMUM PUSHOUT FORCE: .5 LB.
4. MAXIMUM ALLOWABLE BOW: .002 INCH/INCH [MM/MM] AFTER ASSEMBLY.
5. POSITIONS -05, 07 AND -08 WILL HAVE ONLY ONE LOCKING TAB AT DIMENSION SHOWN AND WILL NOT HAVE POLARIZATION NOTCH;  
POSITIONS -10 THROUGH -24 WILL HAVE ONLY ONE LOCKING TAB AT DIMENSION SHOWN;  
POSITIONS -25 THROUGH -34 WILL HAVE TWO LOCKING TABS AT DIMENSION SHOWN;  
POSITIONS -35 THROUGH -50 WILL HAVE THREE LOCKING TABS: TWO AT DIMENSION SHOWN & ONE CENTERED ON INSULATOR.
6. SEE NOTCH FOR PROPER ORIENTATION.
7. PINS CAN BE ORIENTED IN ANY DIRECTION; BOTH ROWS MUST FACE SAME WAY.
8. MAXIMUM PIN HEIGHT VARIATION: .003[0.08] FROM PIN TO PIN AND ROW TO ROW, MUST BE MEASURED BETWEEN ADJACENT PINS.
9. DUE TO THE HIGH AMOUNT OF INSERTION FORCE NEEDED, THE -LC OPTION IS NOT COMPATIBLE WITH AUTO PLACEMENT. SAMTEC RECOMMENDS MANUAL PLACEMENT FOR ALL ASSEMBLIES WITH THE -LC OPTION.
10. TUBE PARTS WITH NOTCH AND/OR LOCKING TAB TOWARD ARROW. NOTCH NOT AVAILABLE ON -05, -07 AND -08 POSITION PARTS.

SECTION "A"- "A"

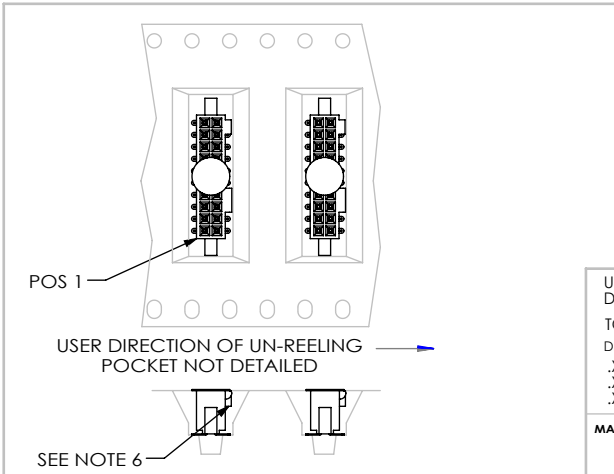
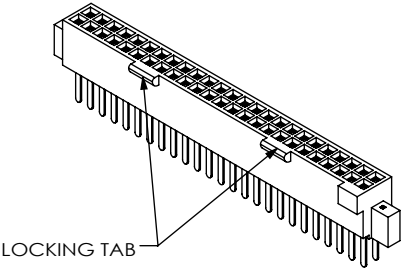

FIG 2

-TR: TAPE & REEL PACKAGING (ALTERNATE KEYING OPTION SHOWN)

TABLE 3 (SEE NOTE 5)

NO OF POS.	"C"
-05, -07	.080 [2.03]
-10 THRU -50	.305 [7.75]



UNLESS OTHERWISE SPECIFIED, DIMENSIONS ARE IN INCHES.

TOLERANCES ARE:

DECIMALS	ANGLES
.XX: ±.01 [0.3]	2°
.XXX: ±.005 [0.13]	
.XXXX: ±.0020 [0.051]	

**PROPRIETARY NOTE**

THIS DOCUMENT CONTAINS CONFIDENTIAL AND PROPRIETARY INFORMATION AND ALL DESIGN, MANUFACTURING, REPRODUCTION, USE, PATENT RIGHTS AND SALES RIGHTS ARE EXPRESSLY RESERVED BY SAMTEC, INC. THIS DOCUMENT SHALL NOT BE DISCLOSED, IN WHOLE OR PART, TO ANY UNAUTHORIZED PERSON OR ENTITY NOR REPRODUCED, TRANSFERRED OR INCORPORATED IN ANY OTHER PROJECT IN ANY MANNER WITHOUT THE EXPRESS WRITTEN CONSENT OF SAMTEC, INC.



520 PARK EAST BLVD, NEW ALBANY, IN 47150  
PHONE: 812-944-6733 FAX: 812-948-5047  
e-Mail: info@SAMTEC.com code: 55322

**MATERIAL:** DO NOT SCALE DRAWING

**INSULATOR:** VECTRA E130I, LCP UL 94 VO  
**COLOR:** BLACK  
**CONTACT:** BeCu  
PHOS BRONZE

SHEET SCALE: 2:1

**DESCRIPTION:**  
.050 [1.27] x .050 [1.27] LOCKING SOCKET ASSEMBLY

DWG. NO.  
**SFML-1XX-XX-XXX-D-XXX**

BY: BRATCHER 4/19/99 SHEET 1 OF 4

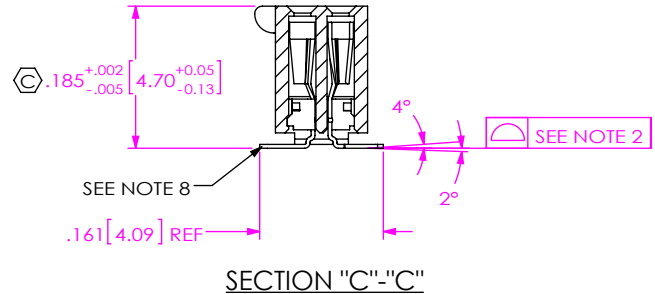
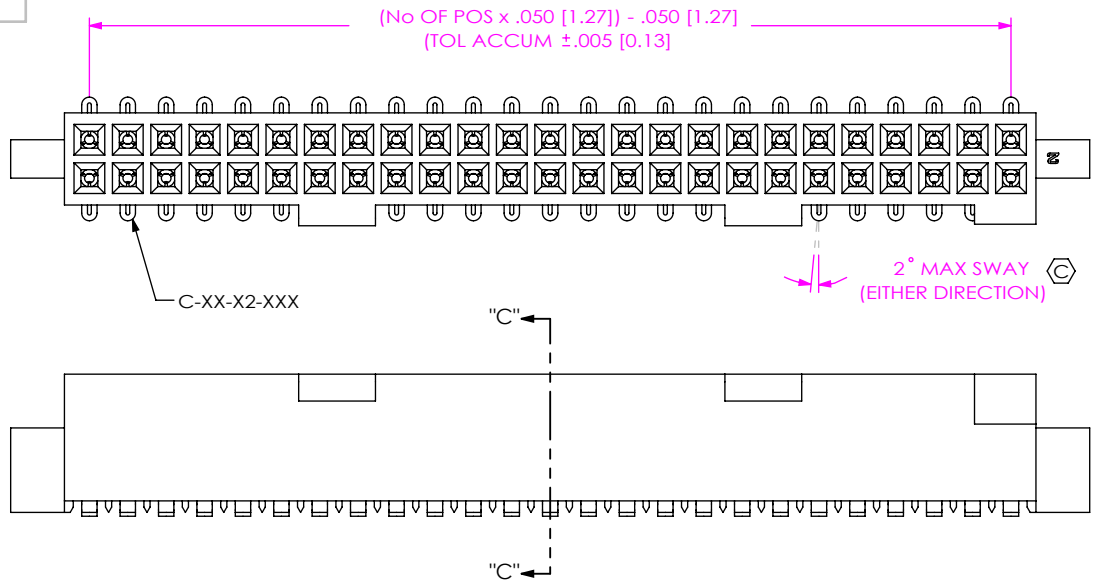
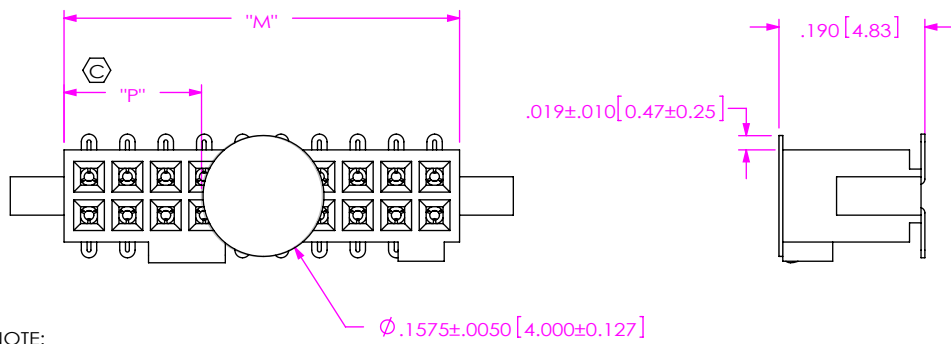
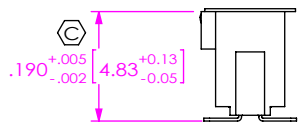

FIG 3  
-X2: SURFACE MOUNT  
(SAME AS FIG 1, UNLESS OTHERWISE STATED)



NOTE:  
"M" = USED MEASURED DIMENSION (REF)  
"P" =  $\{("M" - .1575 [4.000]) / 2\} \pm .020 [0.51]$

FIG 4  
-K: POLYIMIDE FILM PAD OPTION  
(SHOWN: SFML-110-X2-X-D-K)  
(ALTERNATE CONSTRUCTION SHOWN)



DIMENSION APPLIES PRIOR TO RE-PRESS,  
SEE SECTION "C"-"C" FOR FINISHED DIMENSION

IN-PROCESS

F:\DWG\MISC\MKTG\SFML-1XX-XX-XXX-D-XXX-MKT.SLDDRW

**PROPRIETARY NOTE**  
THIS DOCUMENT CONTAINS CONFIDENTIAL AND PROPRIETARY INFORMATION AND ALL DESIGN, MANUFACTURING, REPRODUCTION, USE, PATENT RIGHTS AND SALES RIGHTS ARE EXPRESSLY RESERVED BY SAMTEC, INC. THIS DOCUMENT SHALL NOT BE DISCLOSED, IN WHOLE OR PART, TO ANY UNAUTHORIZED PERSON OR ENTITY NOR REPRODUCED, TRANSFERRED OR INCORPORATED IN ANY OTHER PROJECT IN ANY MANNER WITHOUT THE EXPRESS WRITTEN CONSENT OF SAMTEC, INC.

DO NOT SCALE DRAWING  
SHEET SCALE: 4:1



520 PARK EAST BLVD, NEW ALBANY, IN 47150  
PHONE: 812-944-6733 FAX: 812-948-5047  
e-Mail: info@SAMTEC.com code: 55322

DESCRIPTION:  
.050 [1.27] x .050 [1.27] LOCKING SOCKET ASSEMBLY

DWG. NO.  
SFML-1XX-XX-XXX-D-XXX

BY: BRATCHER 4/19/99 SHEET 2 OF 4

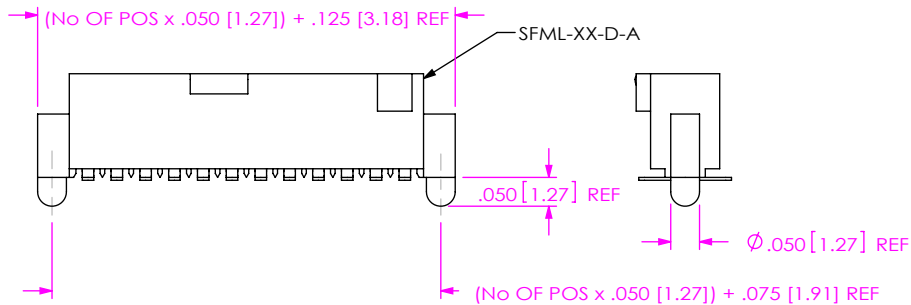

FIG 5

-A: ALIGNMENT PIN OPTION  
(SAME AS FIG 1, UNLESS OTHERWISE STATED)  
(ALTERNATE CONSTRUCTION SHOWN)

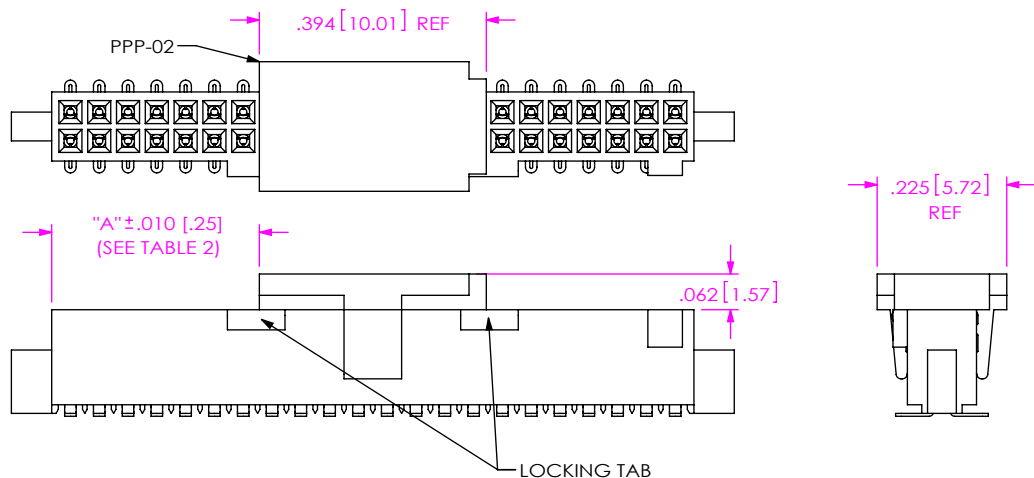
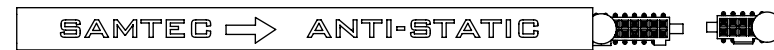
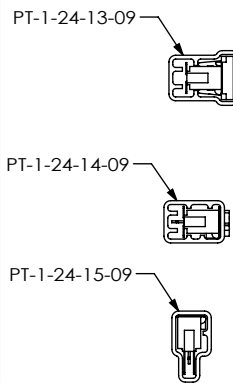

FIG 6

-P: PICK & PLACE PAD OPTION  
(SAME AS FIG 1, UNLESS OTHERWISE STATED)  
(ALTERNATE CONSTRUCTION SHOWN)

TABLE 2	
POS.	"A"
-35 AND ABOVE (ODD)	{{(No OF POS x .050 [1.27]) / 2} -.2895 [7.353]}
EVEN ABOVE -34	{{(No OF POS x .050 [1.27]) / 2} -.3145 [7.989]}
ODD ABOVE -19	{{(No OF POS x .050 [1.27]) / 2} -.1895 [4.813]}
EVEN ABOVE -18	{{(No OF POS x .050 [1.27]) / 2} -.2145 [5.448]}
-07	.065 [1.65] OVERHANG
-10	.086 [2.18]
-11	.136 [3.45]
-12	.186 [4.72]
-13	.236 [5.99]
-14	.286 [7.26]
-15	.086 [2.18]
-16	.136 [3.45]
-17	.186 [4.72]
-18	.236 [5.99]
-19	.286 [7.26]

PACKAGE PARTS IN TUBES AS SHOWN  
(SEE NOTE 10)



LEAD STYLE	PACKAGING TUBE	PLUG
-X1-X, -X3-X (NO PAD)	PT-1-24-15-09	TP-12
-X1-X-P (W/ P&P PAD)	PT-1-24-01-09	TP-24
-X2-X (NO P&P PAD)	PT-1-24-14-09	TP-24-02
-X2-X-P, -X3-X-P (W/ P&P PAD)	PT-1-24-13-09	TP-24
-X1-K	PT-1-24-13-09	TP-24
-X2-K	PT-1-24-14-09	TP-24-02
-X2-SNX	PT-SFM004-X1-X3-D	TP-24-02

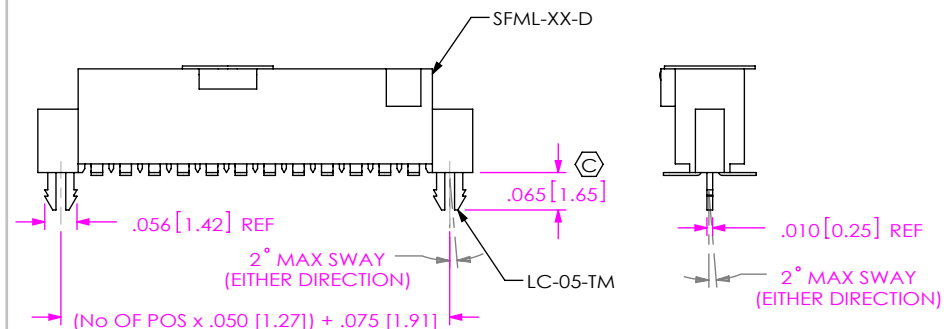

FIG 7  
-LC: LOCKING CLIP OPTION  
(SAME AS FIG 1, UNLESS OTHERWISE STATED)  
(ALTERNATE CONSTRUCTION SHOWN)

**PROPRIETARY NOTE**  
THIS DOCUMENT CONTAINS CONFIDENTIAL AND PROPRIETARY INFORMATION AND ALL DESIGN, MANUFACTURING, REPRODUCTION, USE, PATENT RIGHTS AND SALES RIGHTS ARE EXPRESSLY RESERVED BY SAMTEC, INC. THIS DOCUMENT SHALL NOT BE DISCLOSED, IN WHOLE OR PART, TO ANY UNAUTHORIZED PERSON OR ENTITY NOR REPRODUCED, TRANSFERRED OR INCORPORATED IN ANY OTHER PROJECT IN ANY MANNER WITHOUT THE EXPRESS WRITTEN CONSENT OF SAMTEC, INC.

DO NOT SCALE DRAWING  
SHEET SCALE: 3:1



520 PARK EAST BLVD, NEW ALBANY, IN 47150  
PHONE: 812-944-6733 FAX: 812-948-5047  
e-Mail: info@SAMTEC.com code: 55322

DESCRIPTION:  
.050 [1.27] x .050 [1.27] LOCKING SOCKET ASSEMBLY

DWG. NO.  
SFML-1XX-XX-XXX-D-XXX

BY: BRATCHER 4/19/99 SHEET 3 OF 4

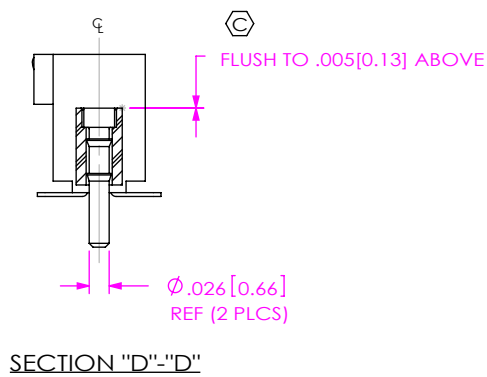
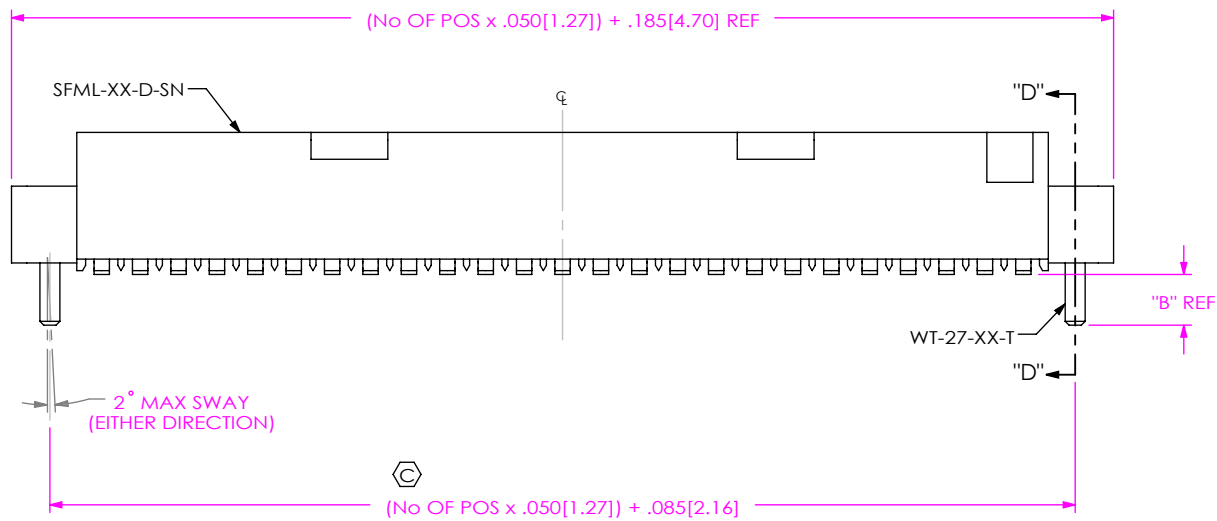

TABLE 3

OPTION	"B"
-SN	.066[1.68]
SN2	.101[1.80]

**FIG 8**  
 -SNX: SOLDER NAIL OPTION  
 (SHOWN: SFML-125-02-XXX-D-SN  
 (SAME AS FIG 1, UNLESS OTHERWISE STATED)  
 (ONLY AVAILABLE ON -X2 LEAD STYLES)

**PROPRIETARY NOTE**  
 THIS DOCUMENT CONTAINS CONFIDENTIAL AND PROPRIETARY INFORMATION AND ALL DESIGN, MANUFACTURING, REPRODUCTION, USE, PATENT RIGHTS AND SALES RIGHTS ARE EXPRESSLY RESERVED BY SAMTEC, INC. THIS DOCUMENT SHALL NOT BE DISCLOSED, IN WHOLE OR PART, TO ANY UNAUTHORIZED PERSON OR ENTITY NOR REPRODUCED, TRANSFERRED OR INCORPORATED IN ANY OTHER PROJECT IN ANY MANNER WITHOUT THE EXPRESS WRITTEN CONSENT OF SAMTEC, INC.

DO NOT SCALE DRAWING

SHEET SCALE: 4:1



520 PARK EAST BLVD, NEW ALBANY, IN 47150  
 PHONE: 812-944-6733 FAX: 812-948-5047  
 e-Mail: info@SAMTEC.com code: 55322

DESCRIPTION:  
 .050 [1.27] x .050 [1.27] LOCKING SOCKET ASSEMBLY

DWG. NO.  
**SFML-1XX-XX-XXX-D-XXX**

BY: BRATCHER 4/19/99 SHEET 4 OF 4