

| COUNT | DESCRIPTION OF REVISIONS | BY  | CHKD | DATE   | COUNT | DESCRIPTION OF REVISIONS | BY | CHKD | DATE |
|-------|--------------------------|-----|------|--------|-------|--------------------------|----|------|------|
| 12    | RE-H-1698                | R.S | T.O  | 96.2.8 |       |                          |    |      |      |
|       |                          |     |      |        |       |                          |    |      |      |
|       |                          |     |      |        |       |                          |    |      |      |

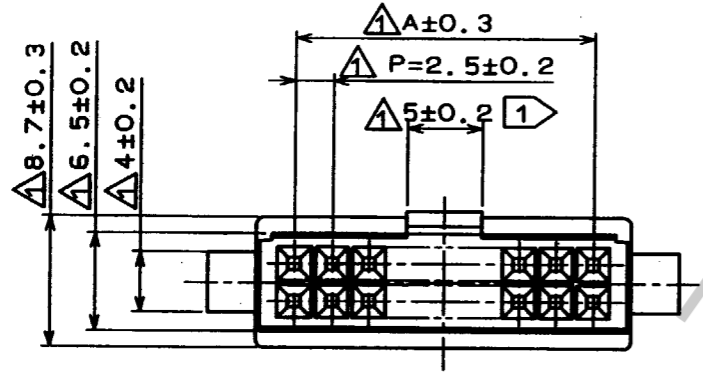

< PANEL CUTOUT >

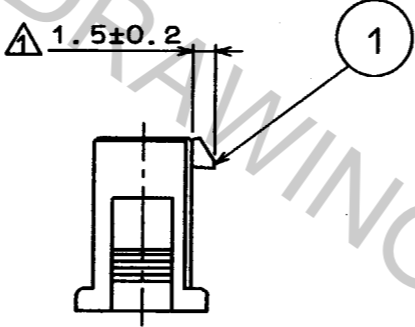
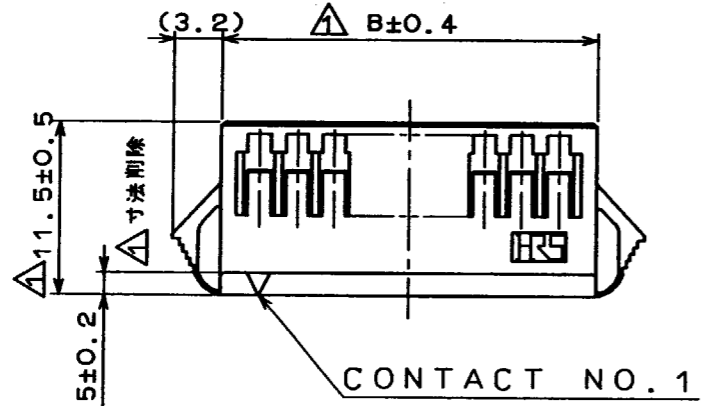
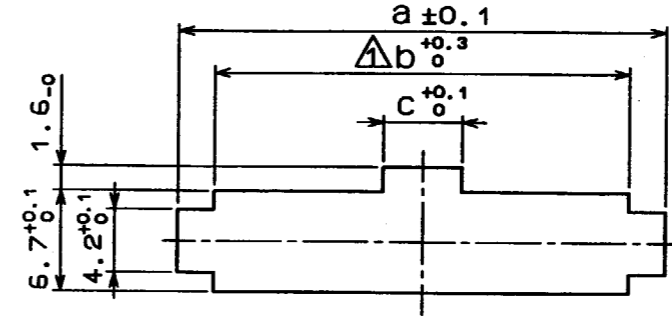

PLEASE NOTE THAT A DIMENSION (PANEL THROUGH HOLE) VARY WITH THICKNESS OF PANEL WHEN YOU MOUNT DF1B EXTENSION SOCKET TO THE PANEL. AND PLEASE PROCESS THE PANEL THROUGH HOLE WITHOUT BURR.

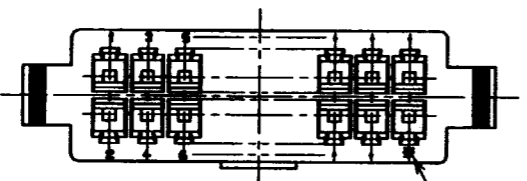

NUMBER OF CONTACTS

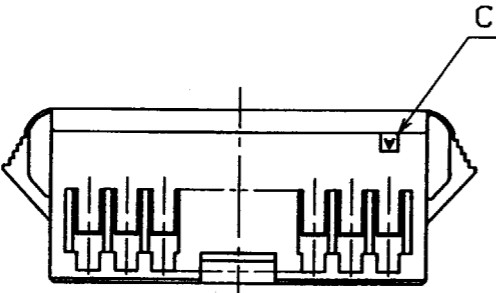

CAVITY NO.

PANEL CUTOUT

| HRS NO.      | PART NO.         | A       |         | B       |      | PANEL THICKNESS |      |     | b | c |
|--------------|------------------|---------|---------|---------|------|-----------------|------|-----|---|---|
|              |                  | A       | B       | a       | a    | a               |      |     |   |   |
|              |                  | 0.5-1.2 | 1.3-1.6 | 1.7-2.0 |      |                 |      |     |   |   |
| CL541-0351-1 | DF1B-10DES-2.5RC | 10.0    | 15.0    | 19.1    | 19.8 | 20.5            | 15.2 | 3.7 |   |   |
| 0352-4       | 12               | 12.5    | 17.5    | 21.6    | 22.3 | 23.0            | 17.7 | 3.7 |   |   |
| 0353-7       | 14               | 15.0    | 20.0    | 24.1    | 24.8 | 25.5            | 20.2 | 3.7 |   |   |
| 0354-0       | 16               | 17.5    | 22.5    | 26.6    | 27.3 | 28.0            | 22.7 | 3.7 |   |   |
| 0346-1       | 18               | 20.0    | 25.0    | 29.1    | 29.8 | 30.5            | 25.2 | 3.7 |   |   |
| 0355-2       | 20               | 22.5    | 27.5    | 31.6    | 32.3 | 33.0            | 27.7 | 5.2 |   |   |
| 0356-5       | 22               | 25.0    | 30.0    | 34.1    | 34.8 | 35.5            | 30.2 | 5.2 |   |   |
| 0357-8       | 24               | 27.5    | 32.5    | 36.6    | 37.3 | 38.0            | 32.7 | 5.2 |   |   |
| 0358-0       | 26               | 30.0    | 35.0    | 39.1    | 39.8 | 40.5            | 35.2 | 5.2 |   |   |
| 0359-3       | 28               | 32.5    | 37.5    | 41.6    | 42.3 | 43.0            | 37.7 | 5.2 |   |   |
| 0360-2       | 30               | 35.0    | 40.0    | 44.1    | 44.8 | 45.5            | 40.2 | 5.2 |   |   |
| 0361-5       | 32               | 37.5    | 42.5    | 46.6    | 47.3 | 48.0            | 42.7 | 5.2 |   |   |
| 0362-8       | 34               | 40.0    | 45.0    | 49.1    | 49.8 | 50.5            | 45.2 | 5.2 |   |   |

10 CONTACTS TO 18 CONTACTS SHALL BE 3.5mm.

|                |                               |                 |                 |           |                        |             |          |
|----------------|-------------------------------|-----------------|-----------------|-----------|------------------------|-------------|----------|
| NO.            | MATERIAL                      | FINISH, REMARKS | 1               | POLYAMIDE | NATURAL(WHITE) UL94V-0 |             |          |
| CODE NO. (OLD) |                               |                 | NO.             | MATERIAL  | FINISH, REMARKS        |             |          |
|                |                               |                 | DRAWN           | DESIGNED  | CHECKED                | APPROVED    | RELEASED |
|                |                               |                 | M. Gotoh        | M. Gotoh  | T. Oma                 | M. Yamamoto |          |
|                |                               |                 | 94 324          | 94 324    | 94 325                 | 94 325      |          |
| SCALE          | DRAWING NO.                   |                 | PART NO.        |           |                        |             |          |
| 2 : 1          | EDC3-160094-02                |                 | DF1B-*DES-2.5RC |           |                        |             |          |
| UNITS          | HRS HIROSE ELECTRIC CO., LTD. |                 | CODE NO.        |           |                        |             |          |
| mm             |                               |                 | 0346 1          |           |                        |             |          |
|                |                               |                 | CL541-0362-8    |           | 1                      |             |          |

Apr. 1. 2017 Copyright 2017 HIROSE ELECTRIC CO., LTD. All Rights Reserved.

|    |
|----|
| TO |
|    |
|    |
|    |