

8/29/89 16:20 • 89241 14:56 • PRELISE • 10-820000/019 0001

4

3

2

1

REVISIONS				
ZONE	LTR	DESCRIPTION	DATE	APPROVED
	C	(CLII) ADDED NOTE 7 ECN: 22391	08/29/89 BURNSIDE	m.n.
	D	(CLII) SEE ECN 27048	6-21-93 RSP	JIB
	E	(CLII) CHANGE BLOCK CHANGE ONLY WAS SHELL 10-617700-XX3 (NO SLOT) ECN: 90078	11-17-04 DEMATTEO	ged

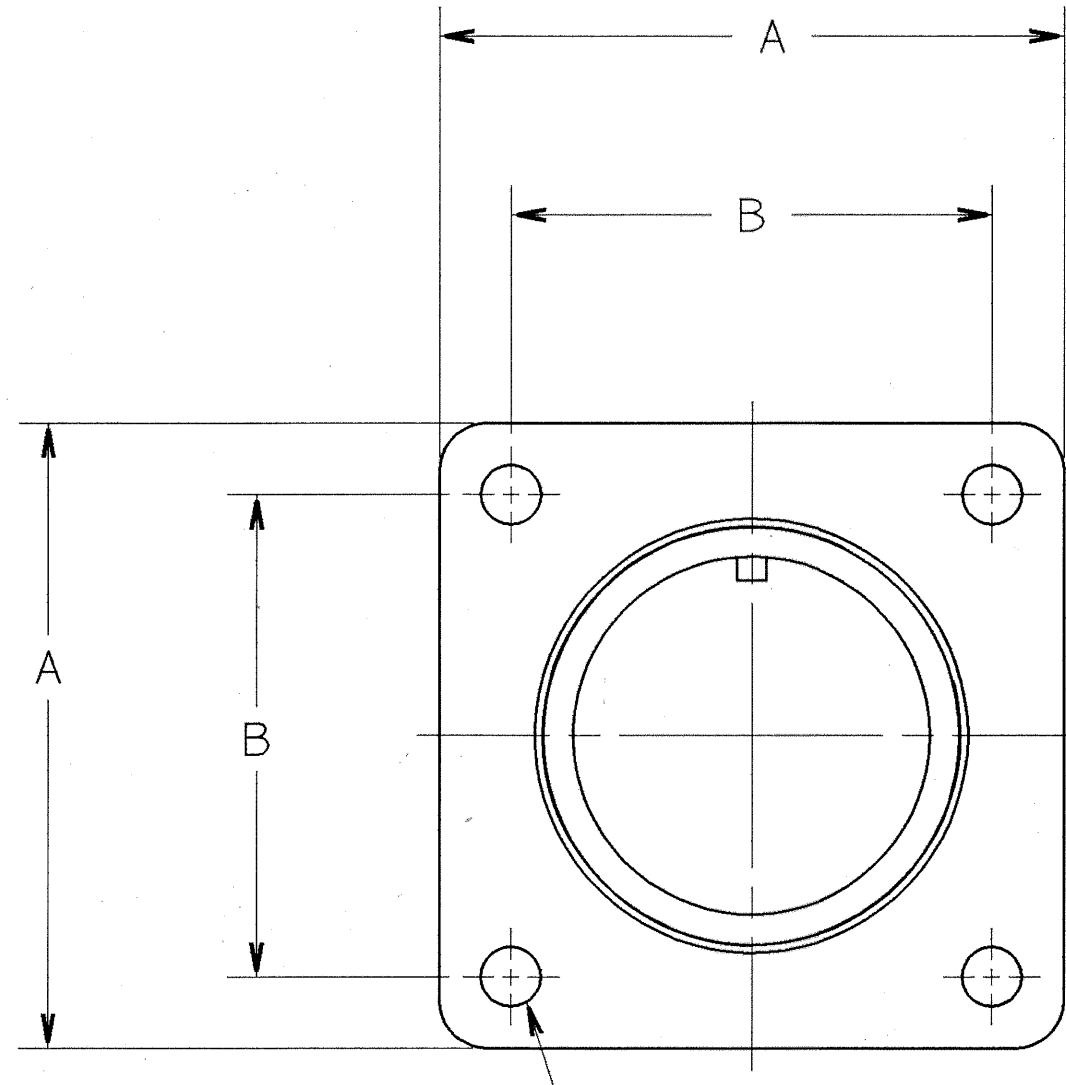

D
4 PLACES

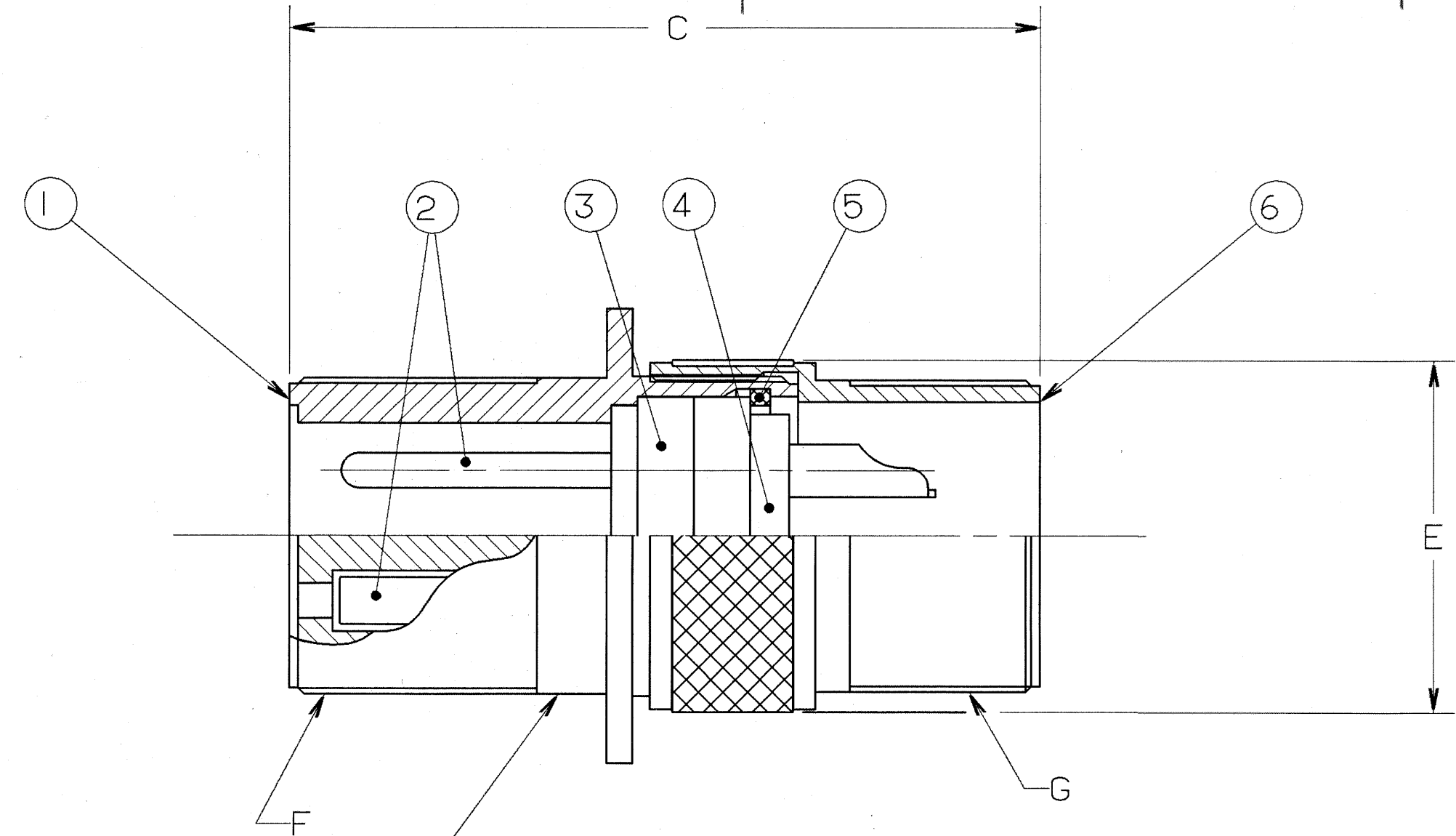

STAMP MS OR AMPHENOL ASSEMBLY (2) (6)
NUMBER ON THIS SURFACE.
CHARACTER HEIGHT .062 MINIMUM.
DATE CODE PER 9-3895.

FIND NO.	QTY RECD.	FSCM NO.	PART NUMBER	DESCRIPTION	NOTE REF.
6	SEE NOTE 1		SEE NOTE 1	BACK SHELL	
5				RING, RETAINING	
4				INSERT, REAR	
3				INSERT, FRONT	
2				CONTACTS	
1				SHELL	

UNLESS OTHERWISE SPECIFIED
LINEAR DIMENSIONS ARE IN
INCHES.
TOLERANCES: .XXX±.010,
.XX ±.03, .X ±.1,
ANGLES ±2°.
OTHER STANDARDS PER 9-3800
AND DOD-D-1000.
NOTE REF. =

PARTS LIST					
SPECIFICATIONS	SIGNATURES	DATES	AMPHENOL CORPORATION BENDIX CONNECTOR OPERATIONS SIDNEY, N.Y.		
MATERIAL SPEC. N/A	PREPARED A. PRESCOTT	11/6/87	CONNECTOR, ELECTRICAL RECEPTACLE, TYPE 97-3100A, OLIVE DRAB CADMIUM PLATED		
	CHECKED PHILPOTT	11/17/87			
PROCESS SPEC. 9-2437-33 9-3895	APPROVED BERNHARDT	11/17/87	SIZE C	FSCM NO. 77820	10-820000/019
	APPROVED HAYNER	11/17/87	SCALE NONE	WT.	REF. N/A
	1ST PART NO. 10-820000-01S				SHEET 1 OF 2

SEE SHEET 2.
NOTES:

THE USE OF THIS DOCUMENT IS UNLIMITED.
HOWEVER, DOCUMENTS REFERENCED HEREON
MAY CONTAIN LIMITED RIGHTS DATA.

N/A
NEXT ASSEMBLY

COMPUTER GENERATED DRAWING.

00000001 01250

TAB.

97-3100A

IMAGED Nov 18 2004 02:46 PM

8/29/89 16:20 * 89241 14:58 * PRELISE * 10-820000/019 0002

4

3

2

1

BENDIX ASSEMBLY NUMBER	AMPHENOL ASSEMBLY NUMBER	MS ASSEMBLY NUMBER	A ±.031	B ±.005	C MAX	D DIA. +.010 -.005	E DIA. MAX	F THREAD	G THREAD
10-820000-()	97-3100A- 8S -()	MS3100A- 8S -()	.875	.594	1.469	.120	.532	.5000-28 UNEF-2A	.5000-28 UNEF-2A
10-820001-()	-10S -()	-10S -()	1.000	.719	1.531		.656	.6250-24 UNEF-2A	.5000-28 UNEF-2A
10-820002-()	-10SL-()	-10SL-()	1.000	.719	1.531		.784	.6250-24 UNEF-2A	.6250-24 UNEF-2A
10-820003-()	-12S -()	-12S -()	1.094	.812	1.688		.782	.7500-20 UNEF-2A	.6250-24 UNEF-2A
10-820004-()	-12SL-()	-12SL-()	NOT AVAILABLE						
10-820005-()	-12 -()	-12 -()	1.094	.812	2.062		.782	.7500-20 UNEF-2A	.6250-24 UNEF-2A
10-820006-()	-14S -()	-14S -()	1.188	.906	1.688		.906	.8750-20 UNEF-2A	.7500-20 UNEF-2A
10-820007-()	-14 -()	-14 -()	1.188	.906	2.062		.906	.8750-20 UNEF-2A	.7500-20 UNEF-2A
10-820008-()	-16S -()	-16S -()	1.281	.969	1.688		1.032	1.0000-20 UNEF-2A	.8750-20 UNEF-2A
10-820009-()	-16 -()	-16 -()	1.281	.969	2.062		1.032	1.0000-20 UNEF-2A	.8750-20 UNEF-2A
10-820010-()	-18 -()	-18 -()	1.375	1.063	2.062		1.156	1.1250-18 UNEF-2A	1.0000-20 UNEF-2A
10-820011-()	-20 -()	-20 -()	1.500	1.156	2.188		1.282	1.2500-18 UNEF-2A	1.1875-18 UNEF-2A
10-820012-()	-22 -()	-22 -()	1.625	1.250	2.188		1.406	1.3750-18 UNEF-2A	1.1875-18 UNEF-2A
10-820013-()	-24 -()	-24 -()	1.750	1.375	2.312	.147	1.532	1.5000-18 UNEF-2A	1.4375-18 UNEF-2A
10-820014-()	-28 -()	-28 -()	2.000	1.563	2.312	.147	1.782	1.7500-18 UNEF-2A	1.4375-18 UNEF-2A
10-820015-()	-32 -()	-32 -()	2.250	1.750	2.438	.173	2.032	2.0000-18 UNEF-2A	1.7500-18 UNEF-2A
10-820016-()	-36 -()	-36 -()	2.500	1.938	2.438		2.282	2.2500-16 UNEF-2A	2.0000-18 UNEF-2A
10-820017-()	-40 -()	-40 -()	2.750	2.188	2.438		2.532	2.5000-16 UN-2A	2.2500-16 UNEF-2A
10-820018-()	-44 -()	-44 -()	NOT AVAILABLE						
10-820019-()	-48 -()	-48 -()	NOT AVAILABLE						

TO COMPLETE, ADD APPLICABLE INSERT ARRANGEMENT SUFFIX PER 9-2437-33. 6

7. IDENTIFY PACKAGE WITH APPLICABLE MS OR 97- PART NUMBER PER NOTE 6.
6. FOR BENDIX INSERT ARRANGEMENT SUFFIX -1 THROUGH -49, STAMP MS ASSEMBLY NUMBER. FOR ALL OTHER INSERT ARRANGEMENT SUFFIX STAMP AMPHENOL ASSEMBLY NUMBER.
5. FOR CONTACT ARRANGEMENT, SEE MIL-STD-1651 AND L-22208-() THROUGH L-22248-().
4. PACKAGE PER PRODUCTION PROCESS SHEET.
3. UNITS MEET THE APPLICABLE REQUIREMENTS OF MIL-C-5015.
2. SEE WORK ORDER FOR PERMISSIBLE ADDITIONAL OR ALTERNATE STAMPING.
1. SEE SEPARATE PARTS LIST FOR COMPONENT PART NUMBERS AND QUANTITIES.

NOTES:

THE USE OF THIS DOCUMENT IS UNLIMITED. HOWEVER, DOCUMENTS REFERENCED HEREON MAY CONTAIN LIMITED RIGHTS DATA.

SIZE	FSCM NO.	REV.
C	77820	E
SCALE	WT.	REF
SHEET		2

COMPUTER GENERATED DRAWING

TAB.

97-3100A

B

A