

DO NOT SCALE FROM THIS PRINT

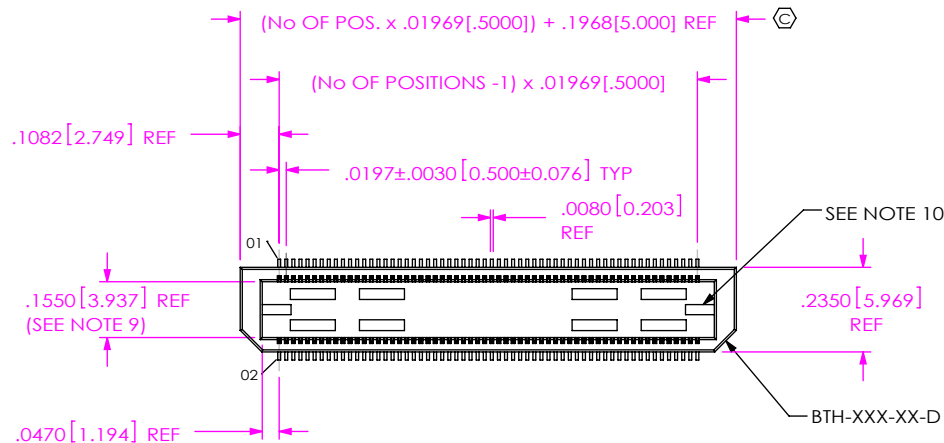

NO OF POSITIONS
 030, ***050, 060, 090,
 *120, *150
 (PER ROW)
 LEAD STYLE -02 ONLY: 030 - 180
 MULTIPLES OF 10

*SEE NOTE 7

LEAD STYLE

- 01: .1680[4.267]
- 02: .2861[7.264]
(030 -180 POSITIONS AVAILABLE)
- 03: .4042[10.267]
- 04: .6000[15.240]
- 05: .7180[18.237]
- 06: .8360[21.234]
- 09: .5224[13.269]

*** = 50 POS. ONLY AVAILABLE FOR
 -01 AND -02 LEAD STYLE
 (REF ASP-65267-02), NOT
 TOOLED FOR -03 LEAD STYLE

OPTION

- A: ALIGNMENT PINS
(USE BTH-XXX-XX-D-A FOR
STYLES -01 & -02)(FOR STYLES
-03 THRU -09, SEE TABLE 4 &
FIG 4, SHEET 3)
- LC: LOCKING CLIPS (SEE NOTE 8)
(USE LC-08-TM-01)
- K: POLYIMIDE FILM
(USE K-DOT-.276-.375-.005, SEE FIG 2)
(AVAILABLE ON STYLES -01
THRU -04 & -09 ONLY)
- TR: TAPE & REEL (120 POS MAX)
[N/A ON -05 THRU -06]

ROW SPECIFICATION

- D: DOUBLE (USE BTH-XXX-XX-D
& BTHH-XXX-XX-D)

PLATING SPECIFICATION

- F: 3µ" SELECTIVE GOLD IN CONTACT
AREA, MATTE TIN ON TAIL
- L: 10µ" SELECTIVE GOLD IN CONTACT
AREA, MATTE TIN ON TAIL
- H: 30µ" GOLD IN CONTACT AREA,
3µ" GOLD ON TAIL
- C: 50µ" GOLD IN CONTACT AREA,
MATTE TIN ON TAIL

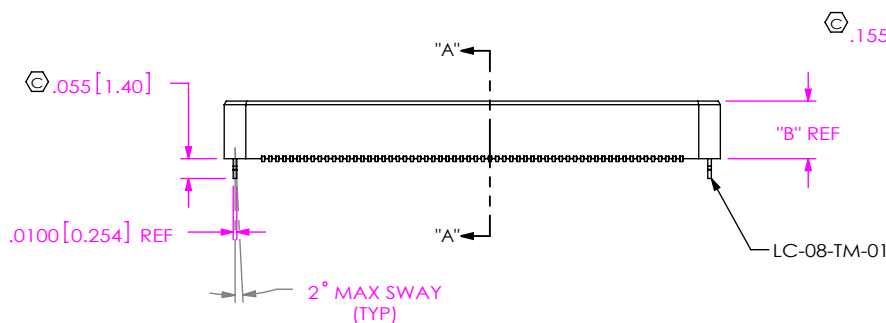

-LC: LOCKING CLIP OPTION SHOWN

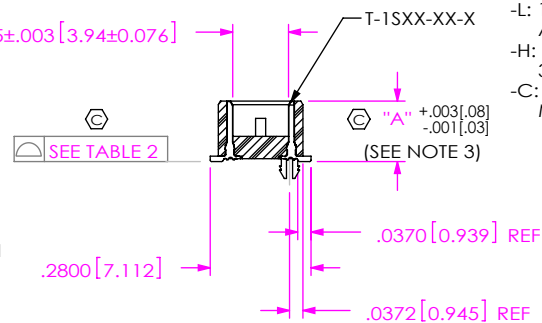

SECTION "A"- "A"

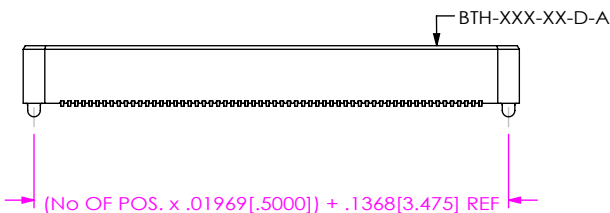
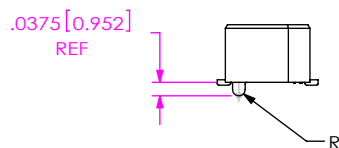

-A: ALIGNMENT PIN OPTION SHOWN

NOTES:

1. ⊕ REPRESENTS A CRITICAL DIMENSION.
2. MINIMUM PUSHOUT FORCE: 6 OZ. FOR STYLES -01 & -02
8 OZ. FOR STYLES -03 THRU -09
3. MAXIMUM VARIANCE: .002[.05].
4. LEAD STYLES -03 THRU -09: TOP BODY (BTH)
CANNOT HAVE -A OPTION.
5. -L PLATING CAN BE SUBSTITUTED FOR -F PLATING.
6. NOTE DELETED.
7. FOR NEW APPLICATIONS REQUIRING THESE POSITIONS, PLEASE
CONTACT SAMTEC INTERCONNECT PROCESSING GROUP.
8. DUE TO THE HIGH AMOUNT OF INSERTION FORCE NEEDED, THE
-LC OPTION IS NOT COMPATIBLE WITH AUTO PLACEMENT.
SAMTEC RECOMMENDS MANUAL PLACEMENT FOR ALL
ASSEMBLIES WITH THE -LC OPTION.
9. PIN CAN EXTEND PAST THE WALL: .003[.08].
10. FEATURE PRESENT ONLY ON -01 LEAD STYLE.
11. GATE PAD PRESENT ON BTH-XXX-02-D-X ONLY.

NO. OF POSITIONS	COPLANARITY
-030 THRU -090	.004[.10]
-120 THRU -150	.006[.15]

STYLE	"A"	"B"	BODY	TERMINAL	MATED HEIGHT WITH BSH
-01	.1680[4.267]	.1600[4.064]	BTH-XXX-01-D(-A)	T-1S39-01-X	.1969[5.001] REF
-02	.2861[7.267]	.2781[7.064]	BTH-XXX-02-D(-A)	T-1S59-02-X	.3150[8.001] REF

UNLESS OTHERWISE SPECIFIED,
 DIMENSIONS ARE IN INCHES.
 TOLERANCES ARE:
 DECIMALS ANGLES
 .XX: ±.01[.3]
 .XXX: ±.005[.13]
 .XXXX: ±.0020[.051]

PROPRIETARY NOTE
 THIS DOCUMENT CONTAINS CONFIDENTIAL AND
 PROPRIETARY INFORMATION AND ALL DESIGN,
 MANUFACTURING, REPRODUCTION, USE, PATENT RIGHTS
 AND SALES RIGHTS ARE EXPRESSLY RESERVED BY SAMTEC,
 INC. THIS DOCUMENT SHALL NOT BE DISCLOSED, IN WHOLE
 OR PART, TO ANY UNAUTHORIZED PERSON OR ENTITY NOR
 REPRODUCED, TRANSFERRED OR INCORPORATED IN ANY
 OTHER PROJECT IN ANY MANNER WITHOUT THE EXPRESS
 WRITTEN CONSENT OF SAMTEC, INC.



520 PARK EAST BLVD, NEW ALBANY, IN 47150
 PHONE: 812-944-6733 FAX: 812-948-5047
 e-Mail: info@SAMTEC.com code: 55322

MATERIAL: DO NOT SCALE DRAWING SHEET SCALE: 1:0.533333 DESCRIPTION:
 INSULATOR: BLACK LCP
 FLAMMABILITY RATING: UL 94V-0
 .5mm DOUBLE ROW TERMINAL ASSEMBLY
 DWG. NO. BTH-XXX-XX-X-D-XX
 TERMINAL: PHOS BRONZE
 BY: DEAN P 5/28/1999 SHEET 1 OF 3
 F:\DWG\MISC\MKTG\BTH-XXX-XX-X-D-XX-MKT.SLDDRW

FIG 2
-K: POLYIMIDE FILM PAD OPTION

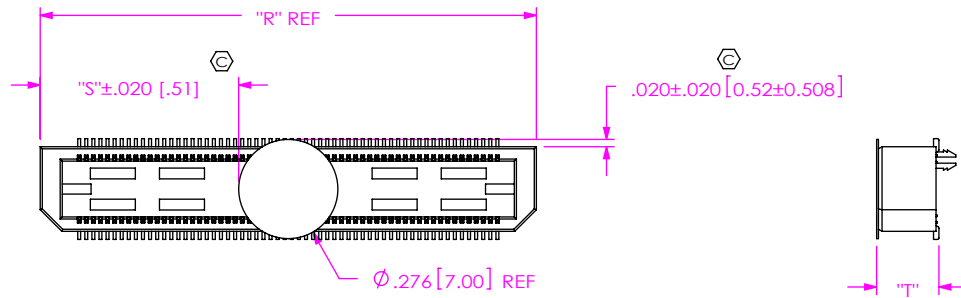

TABLE 3	
STYLE	"T"
-01	.173[4.39]
-02	.291[7.39]
-03	.409[10.39]
-04	.605[15.37]
-09	.527[13.39]

NOTE: "R" = (No OF POSITIONS x .01969[.5000]) + .1968[5.000]
 "S" = (("R" - .276[7.01]) / 2) ±.020[.51]

PACKAGING VIEW (PARTS TO HAVE POSITIOIN #01 LOADED IN SAME DIRECTION AS ARROW)			
[STYLES -01 & -02]	[STYLES -03, -04, & -09]	[STYLE -05]	[STYLE -06]
TUBE: PT-1-24-01-78 PLUG: TP-03	TUBE: PT-1-24-01-98 PLUG: TP-26	TUBE: PT-1-24-02-105 PLUG: TP-26	TUBE: PT-1-24-01-105 PLUG: TP-26

F:\DWG\MISC\MKTG\BTH-XXX-XX-X-D-XX-MKT.SLDDRW

PROPRIETARY NOTE
 THIS DOCUMENT CONTAINS CONFIDENTIAL AND PROPRIETARY INFORMATION AND ALL DESIGN, MANUFACTURING, REPRODUCTION, USE, PATENT RIGHTS AND SALES RIGHTS ARE EXPRESSLY RESERVED BY SAMTEC, INC. THIS DOCUMENT SHALL NOT BE DISCLOSED, IN WHOLE OR PART, TO ANY UNAUTHORIZED PERSON OR ENTITY NOR REPRODUCED, TRANSFERRED OR INCORPORATED IN ANY OTHER PROJECT IN ANY MANNER WITHOUT THE EXPRESS WRITTEN CONSENT OF SAMTEC, INC.

DO NOT SCALE DRAWING

SHEET SCALE: 1.875:1



520 PARK EAST BLVD, NEW ALBANY, IN 47150
 PHONE: 812-944-6733 FAX: 812-948-5047
 e-Mail: info@SAMTEC.com code: 55322

DESCRIPTION:
 .5mm DOUBLE ROW TERMINAL ASSEMBLY

DWG. NO.
BTH-XXX-XX-X-D-XX

BY: DEAN P 5/28/1999 SHEET 2 OF 3

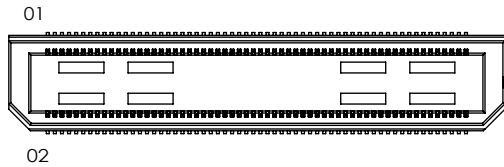

TABLE 4							
STYLE	SEE FIGURE	"C" OVERALL HEIGHT	TERMINAL	TOP BODY (SEE NOTE 4)	BOTTOM SPACER BODY (-LC OR NONE)	BOTTOM SPACER BODY (-A)	MATED HEIGHT WITH BSH-01
-03	3	.4042 [10.267]	T-1S60-03-X	BTH-XXX-02-D	BTHH-XXX-01-D	BTHH-XXX-01-D-A	.433 [11.00] REF
-04	3	.6000 [15.240]	T-1S60-04-X	BTH-XXX-02-D	BTHH-XXX-01-D	BTHH-XXX-01-D-A	.630 [16.00] REF
-05	4	.7180 [18.237]	T-1S60-05-X	BTH-XXX-02-D	BTHH-XXX-03-D	BTHH-XXX-03-D-A	.748 [19.00] REF
-06	4	.8360 [21.234]	T-1S60-06-X	BTH-XXX-02-D	BTHH-XXX-03-D	BTHH-XXX-03-D-A	.866 [22.00] REF
-09	3	.5224 [13.269]	T-1S60-09-X	BTH-XXX-02-D	BTHH-XXX-01-D	BTHH-XXX-01-D-A	.551 [14.00] REF

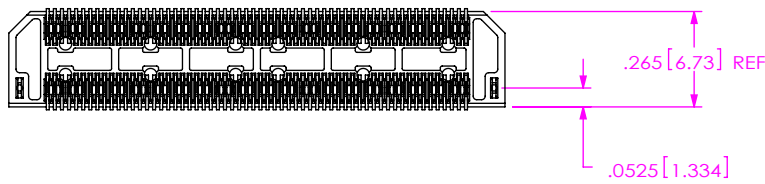
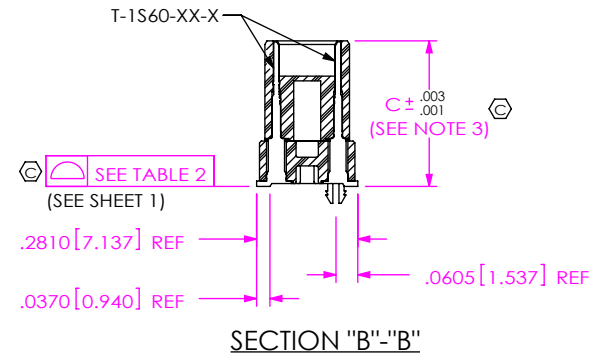
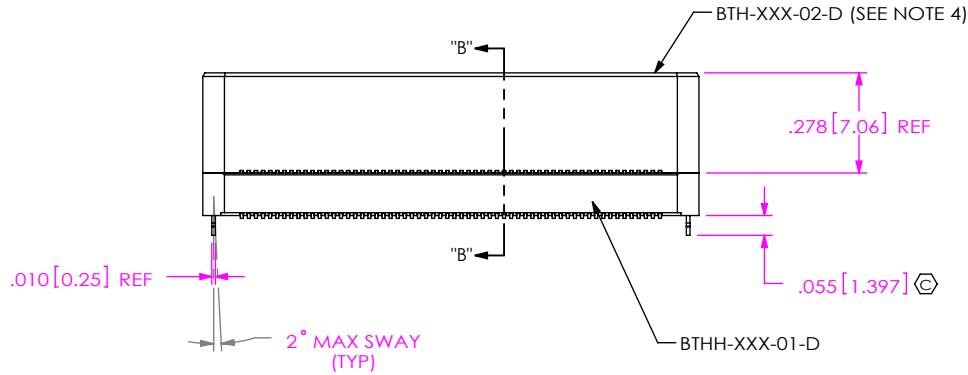

FIG 3
BTH-060-03-X-D-LC SHOWN (STYLES -03, -04, & -09)
(DIFFERENT AS SHOWN, OTHERWISE SAME AS FIG 1)

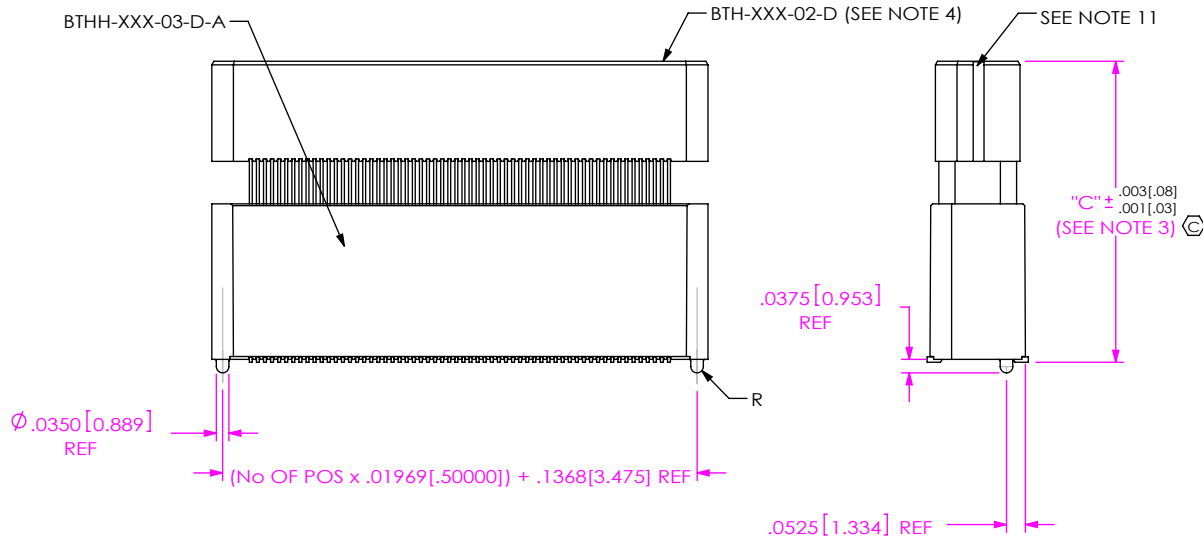

FIG 4
-A: ALIGNMENT PIN OPTION
BTH-060-06-X-D-A SHOWN (STYLES -05 & -06)
(DIFFERENT AS SHOWN, OTHERWISE SAME AS FIG 1)

F:\DWG\MISC\MKTG\BTH-XXX-XX-X-D-XX-MKT.SLDDRW

PROPRIETARY NOTE
THIS DOCUMENT CONTAINS CONFIDENTIAL AND PROPRIETARY INFORMATION AND ALL DESIGN, MANUFACTURING, REPRODUCTION, USE, PATENT RIGHTS AND SALES RIGHTS ARE EXPRESSLY RESERVED BY SAMTEC, INC. THIS DOCUMENT SHALL NOT BE DISCLOSED, IN WHOLE OR PART, TO ANY UNAUTHORIZED PERSON OR ENTITY NOR REPRODUCED, TRANSFERRED OR INCORPORATED IN ANY OTHER PROJECT IN ANY MANNER WITHOUT THE EXPRESS WRITTEN CONSENT OF SAMTEC, INC.

DO NOT SCALE DRAWING
SHEET SCALE: 1:0.533333



520 PARK EAST BLVD, NEW ALBANY, IN 47150
PHONE: 812-944-6733 FAX: 812-948-5047
e-Mail: info@SAMTEC.com code: 55322

DESCRIPTION:
.5mm DOUBLE ROW TERMINAL ASSEMBLY
DWG. NO.
BTH-XXX-XX-X-D-XX
BY: DEAN P 5/28/1999 SHEET 3 OF 3