

DO NOT SCALE FROM THIS PRINT

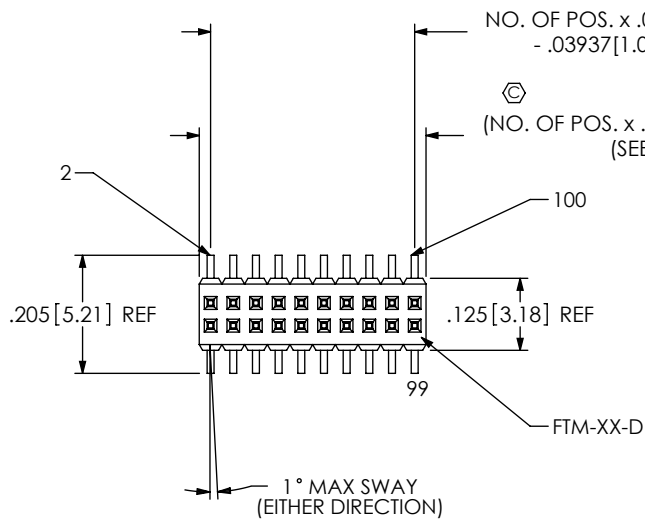

FTM-1XX-XX-XX-DV-XX

- No OF POSITIONS (PER ROW)**
 -02 THRU -50 (UNSHROUDED)
 -05 THRU -46 (SHROUDED)
- LEAD STYLE**
 -02: .075 [1.91] POST HEIGHT
 -03: .065 [1.65] POST HEIGHT
- PLATING SPECIFICATION**
 -F: FLASH SELECTIVE (USE T-1S16-XX-F-2)
 -L: LIGHT SELECTIVE (USE T-1S16-XX-L-2)
 -H: HEAVY GOLD (USE T-1S16-XX-H-2)
 -G: GOLD (USE T-1S16-XX-G-2)
 -FM: FLASH GOLD W/ MATTE TIN TAILS (USE T-1S16-XX-F-2)
 -LM: LIGHT GOLD W/ MATTE TIN TAILS (USE T-1S16-XX-L-2)
- OPTION**
 -TR: TAPE & REEL PACKAGING
 -P: PICK AND PLACE PAD (USE PPP-30) (USE PPP-30-NT FOR TAPE & REEL) (AVAILABLE ON POSITIONS -07 THRU -50) (SEE FIG 4, SHT 3)
 -S: END SHROUDS (05 POS. MINIMUM) (SEE NOTE 8) (SEE NOTE 9)
 PRESS FIT SHROUDS: SEE FIG 2
 MOLDED SHROUDS: SEE FIG 6
 -SA: END SHROUDS W/ ALIGNMENT PINS (SEE FIG 3, SHT. 2) (SEE NOTE 9) (05 POS PER ROW MINIMUM, 46 POS PER ROW MAXIMUM) (USE FTM-XX-D, USE FTMH-75-D-ES-XX-X FOR MOLDED END SHROUDS)
- ROW OPTION**
 -DV: DUAL VERTICAL

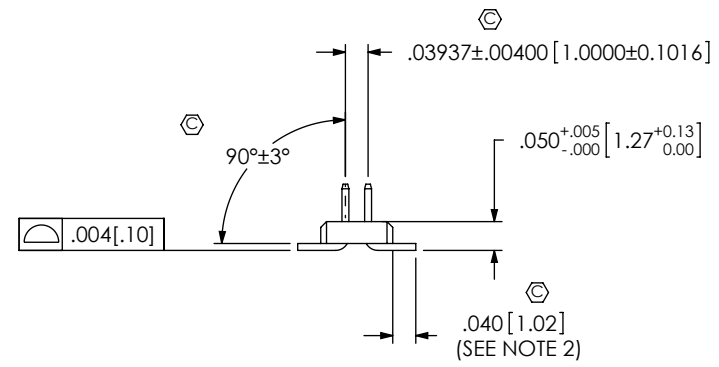
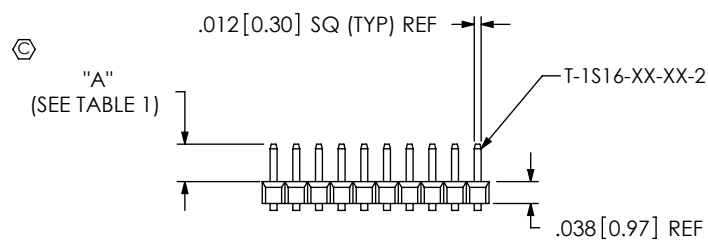
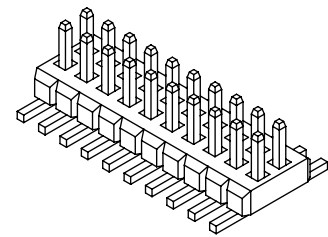

FIG 1
FTM-1XX-02-X-DV SHOWN

NOTES:

- PARTS MAY BE CUT TO POSITION; .010 MAX CUT FLASH
- SHEAR TAILS TO DIMENSION SHOWN; .003 MAX BURR.
- NOTE DELETED.
- ⊙ REPRESENTS A CRITICAL DIMENSION FOR STATISTICAL PROCESS CONTROL.
- NOTE DELETED.
- NOTE DELETED.
- POSITIONS -02 THRU -04 TO BE LAYER PACKAGED, AND POSITIONS -05 THRU -50 TO BE TUBE PACKAGED.
- PARTS WITH -S OPTION ARE TO APPEAR AS SHOWN IN FIG 2 OR FIG 6 AT SAMTEC'S DISCRETION.
- 4 POSITIONS MUST BE ADDED TO PART CALL OUT TO ALLOW FOR PUSH ON SHROUDS.
EX: FTM-125-02-L-DV-S REQUIRES A 29 POSITION STRIP.
- MINIMUM PUSHOUT FORCE: .5 LB (8 OZ)



PATENT NUMBERS
5655914 / 5785536

CRITICAL DIMENSION INSPECTION INSTRUCTION TABLE	
ASSEMBLY OPERATION	IN PROCESS INSPECTION
AUTO FILL T-1S16-XX-XX-2	C1, C3 C5, C6, C8
CUT TO POSITION	C2, C7
INSTALL FEM	C9, C10, C16
INSTALL FEM-A	C12
INSTALL PICK AND PLACE PAD	C13
CPC'S INTENTIONALLY DELETED: C4, C11, C14, C15	

LEAD STYLE	"A"	TERMINAL
-02	.075 [1.91]	T-1S16-03-XX-2
-03	.065 [1.65]	T-1S16-04-XX-2

UNLESS OTHERWISE SPECIFIED, DIMENSIONS ARE IN INCHES. TOLERANCES ARE: DECIMALS ANGLES .XX: ±.01 [.3] 3° .XXX: ±.005 [.13] .XXXX: ±.0020 [.051]	PROPRIETARY NOTE THIS DOCUMENT CONTAINS INFORMATION CONFIDENTIAL AND PROPRIETARY TO SAMTEC, INC. AND SHALL NOT BE REPRODUCED OR TRANSFERRED TO OTHER DOCUMENTS OR DISCLOSED TO OTHERS OR USED FOR ANY PURPOSE OTHER THAN THAT WHICH IT WAS OBTAINED WITHOUT THE EXPRESSED WRITTEN CONSENT OF SAMTEC, INC.		
		520 PARK EAST BLVD, NEW ALBANY, IN 47150 PHONE: 812-944-6733 FAX: 812-948-5047 e-Mail: info@SAMTEC.com code: 55322	
MATERIAL: DO NOT SCALE DRAWING BODY: VECTRA E130 COLOR: BLACK TERMINAL: PHOS BRONZE	MAX FLASH ALLOWED: .002 [.05] MAX GATE VESTIGE ALLOWED: .002 [.05]	DESCRIPTION: 1mm x 1mm LOW PROFILE SMT STRIP ASM DWG. NO. FTM-1XX-XX-XX-DV-XX	
F:\DWG\MISC\MKTG\FTM-1XX-XX-XX-DV-XX-MKT.SLDDRW		BY: B MENEAR 2/13/2006	SHEET 1 OF 3

FIG 2

-S OPTION
FTM-1XX-02-X-DV-S SHOWN
(DIFFERENT AS SHOWN, OTHERWISE SAME AS FIG 1) (SEE NOTE 8) (SEE NOTE 9)
(PRESS FIT SHROUDS TO HAVE 8 UNUSED SOLDER TAILS AS SHOWN)

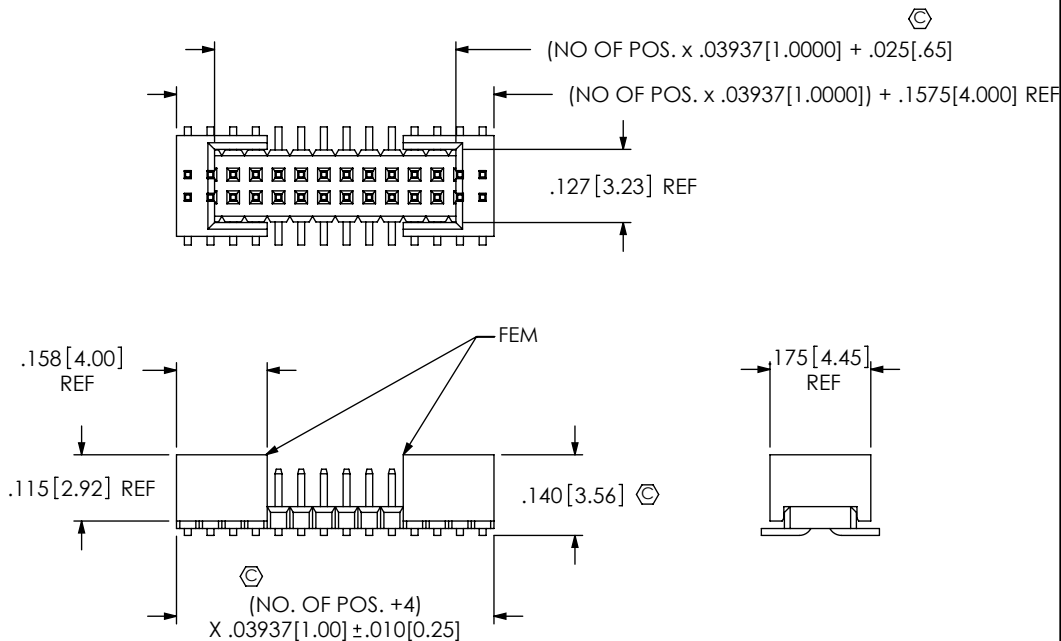

FIG 3

-SA SHOWN: PRESS FIT SHROUD
FTM-1XX-02-X-DV-SA
(DIFFERENT AS SHOWN, OTHERWISE SAME AS FIG 1)
(SEE NOTE 9)

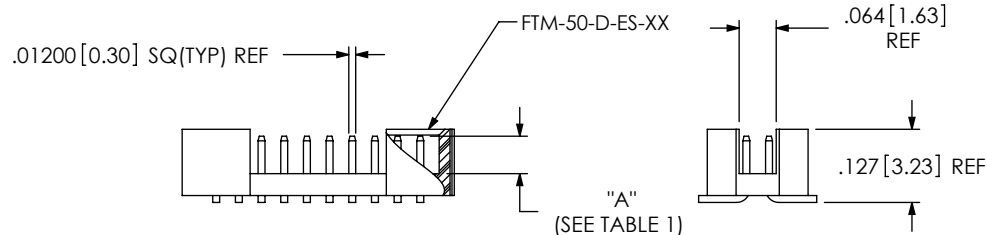
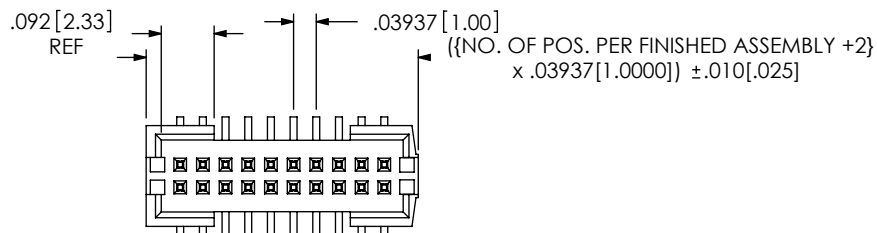
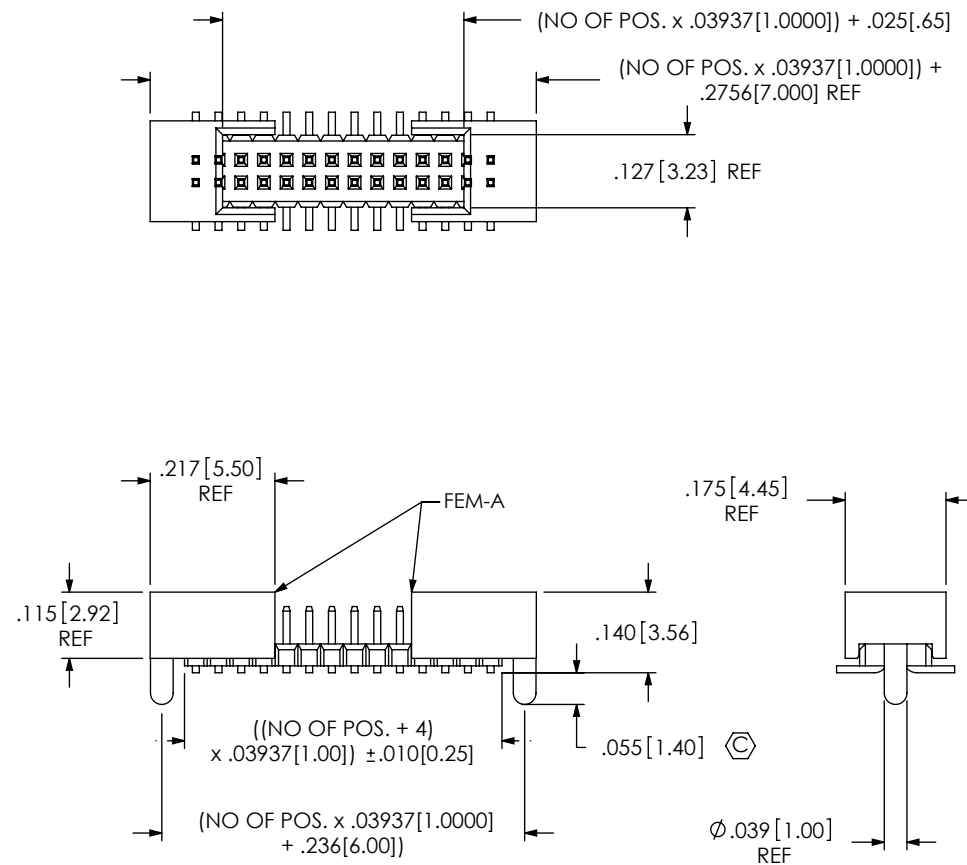

FIG 6

-S OPTION: MOLDED SHROUD
FTM-1XX-02-X-DV-S SHOWN
(DIFFERENT AS SHOWN, OTHERWISE SAME AS FIG 1)(SEE NOTE 8)

PROPRIETARY NOTE
THIS DOCUMENT CONTAINS INFORMATION
CONFIDENTIAL AND PROPRIETARY TO
SAMTEC, INC. AND SHALL NOT BE REPRODUCED
OR TRANSFERRED TO OTHER DOCUMENTS OR
DISCLOSED TO OTHERS OR USED FOR ANY
PURPOSE OTHER THAN THAT WHICH IT WAS
OBTAINED WITHOUT THE EXPRESSED WRITTEN
CONSENT OF SAMTEC, INC.

DO NOT SCALE DRAWING

SHEET SCALE: 2:1

samtec

520 PARK EAST BLVD, NEW ALBANY, IN 47150
PHONE: 812-944-6733 FAX: 812-948-5047
e-Mail: info@SAMTEC.com code: 55322

DESCRIPTION:
1mm x 1mm LOW PROFILE SMT STRIP ASM

DWG. NO.
FTM-1XX-XX-XX-DV-XX

BY: B MENEAR 2/13/2006 SHEET 2 OF 3

FIG 4

(DIFFERENT AS SHOWN, OTHERWISE SAME AS FIG 1)

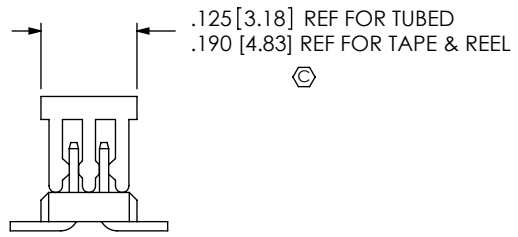
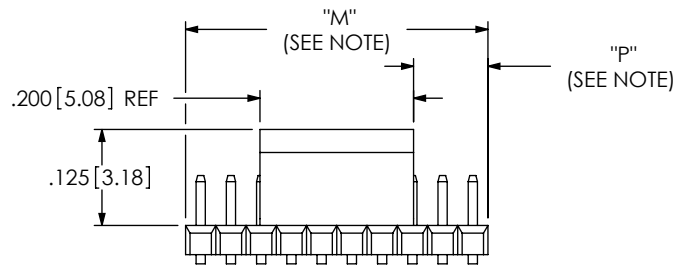

NOTE: "M" = USED MEASURED DIMENSION (REF)
 "P" = {"M" - .200 [5.08]} / 2} +/- .020 [.51]

PACKAGING VIEW

(SEE NOTE 7)

NOTE:
 ONLY POSITIONS -05 THRU -50 ARE TO BE TUBED. POSITIONS -02 THRU -04 TO BE LAYER PACKAGED ONLY. INSERT PLUG TP-30 AT AN ANGLE INTO PT-1-24-01-49, PLUG MUST SUPPORT THE INSULATOR.

PACKAGING TABLE		
OPTIONS	PACKAGING TUBE	PLUGS
W/O OPTION	PT-1-24-01-49	TP-30
-P	PT-1-24-01-43	TP-24
-S, -S-P, -SA, -SA-P	PT-1-24-13-09	TP-24

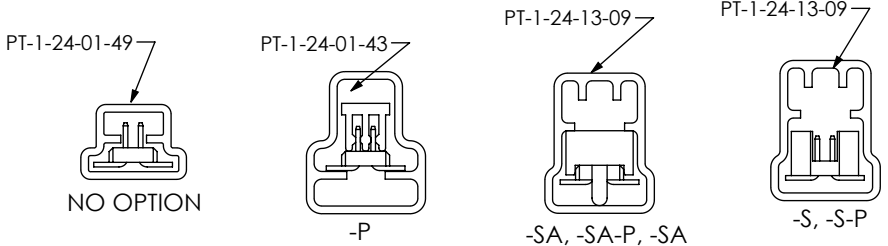

F:\DWG\MISC\MKTG\FTM-1XX-XX-XX-DV-XX-MKT.SLDDRW

PROPRIETARY NOTE
 THIS DOCUMENT CONTAINS INFORMATION CONFIDENTIAL AND PROPRIETARY TO SAMTEC, INC. AND SHALL NOT BE REPRODUCED OR TRANSFERRED TO OTHER DOCUMENTS OR DISCLOSED TO OTHERS OR USED FOR ANY PURPOSE OTHER THAN THAT WHICH IT WAS OBTAINED WITHOUT THE EXPRESSED WRITTEN CONSENT OF SAMTEC, INC.

DO NOT SCALE DRAWING

SHEET SCALE: 4:1

samtec

520 PARK EAST BLVD, NEW ALBANY, IN 47150
 PHONE: 812-944-6733 FAX: 812-948-5047
 e-Mail: info@SAMTEC.com code: 55322

DESCRIPTION:
 1mm x 1mm LOW PROFILE SMT STRIP ASM

DWG. NO. **FTM-1XX-XX-XX-DV-XX**

BY: B MENEAR 2/13/2006 SHEET 3 OF 3